



Stationary mixing technology

Verti-Mix, stationary





Verti-Mix S

Verti-Mix S

Optimum mixing results – Thanks to the Verti-Mix S

For semi-automated feeding systems, Strautmann combines the experience gathered in the field of towed fodder mixing wagons with that gained from working with dosage systems for biogas plants. The stationary Verti-Mix series equipped with an electric drive is the result. The convincing characteristics of the towed fodder mixing wagons have also been implemented in the stationary mixers:

- Easy towing
- Homogeneous mixing
- Short mixing time

Just like the towed mixing wagons, the stationary Verti-Mix models are also equipped with an extension concept for flexible increase of volume.



Technical modifications reserved

Verti-Mix S installation options

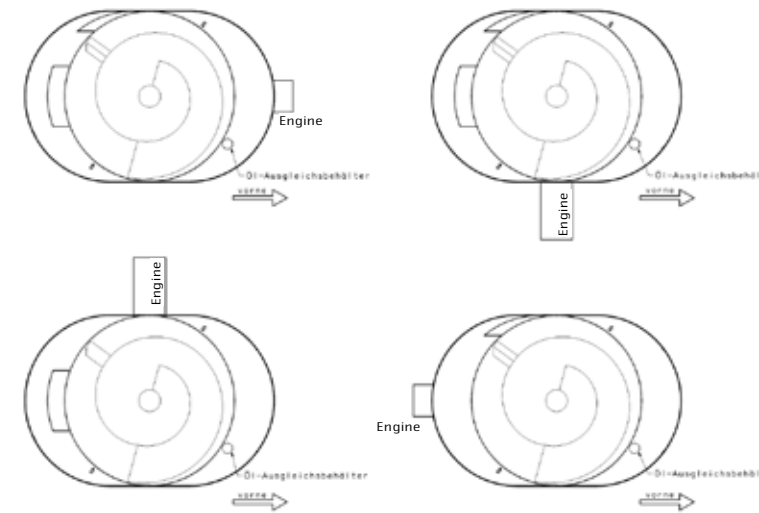

The various installation options enable optimum adaptation to the existing infrastructure.

Engine options for Verti-Mix S:

- VM 951: 22 KW, 263 rpm
- VM 1651: 22 KW, 230 rpm

Engine options for Verti-Mix Double S:

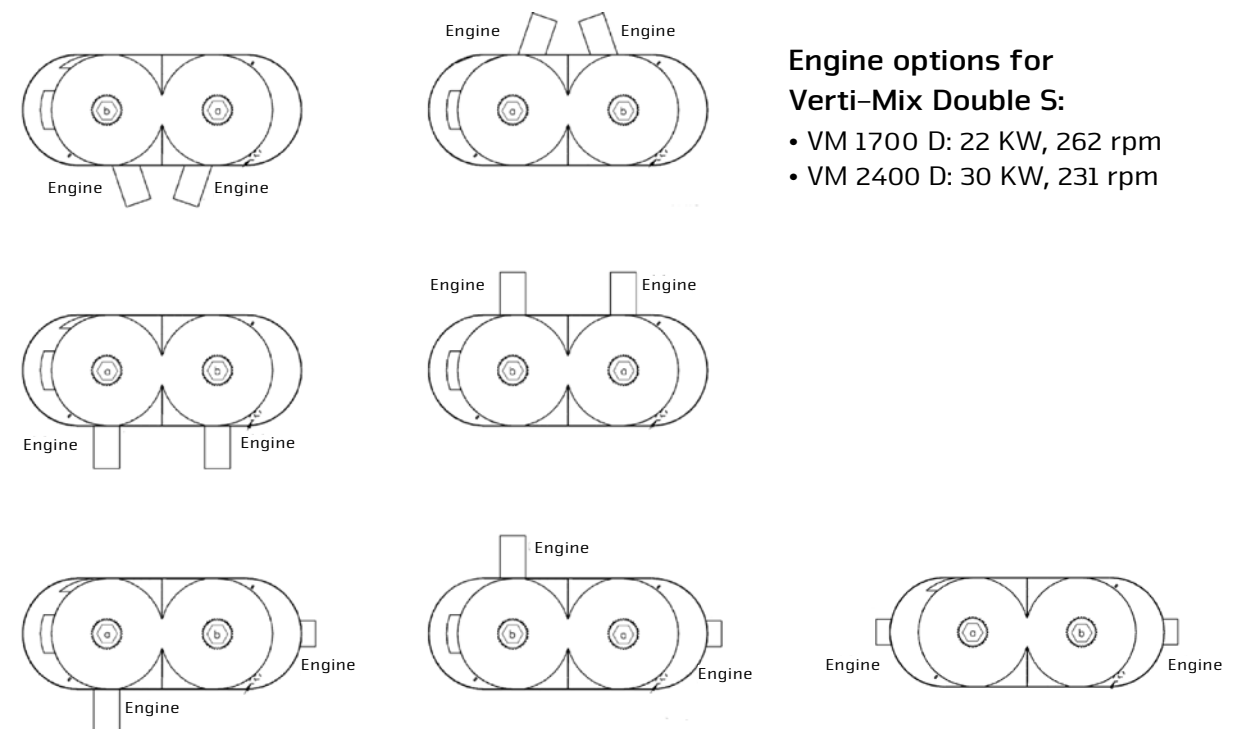

Engine options for Verti-Mix Double S:

- VM 1700 D: 22 KW, 262 rpm
- VM 2400 D: 30 KW, 231 rpm

Operation:



Basic model:

- Standard
- Casing for hydraulic unit and control box

The allround talent

- IMS (Intensive Mix System) mixing auger

The IMS mixing auger – Variability and strength for any purpose

Due to the patented knife adjustment system, the IMS mixing auger can be perfectly adapted to your specific conditions of use. The robust and low-maintenance angular gear ensures long service life even under challenging conditions.

Strautmann Verti-Mix fodder mixing wagons substantially contribute to increase the productivity of modern dairy farms. The perfect geometry of container and IMS mixing auger is supported by the newly developed mixing auger in stepped flight design with 60-degree elements. This ensures:

- Low power requirement
- Preservation of fodder structure
- Homogeneous mixing
- Energy-saving, short mixing times

Excellent mixing quality and proven easy towing guarantee absolute cost-effectiveness for any kind of application.



Adjustable front auger end/scrapper
Due to adjustable scraper bars at the front auger end and at the scrapper, even finest ingredients are reliably picked up from the ground and homogeneously mixed.



Robust core

The core of the IMS mixing auger is the very robust and durable gearbox. Stability and long maintenance intervals are achieved by means of a large-sized pair of tapered rollers, double sealing and a large grease chamber.



Effective mixing

The perfect harmonisation of mixing auger geometry and the distance to the container wall form the basis for quick and homogeneous mixing.

Extend service life – Save money!

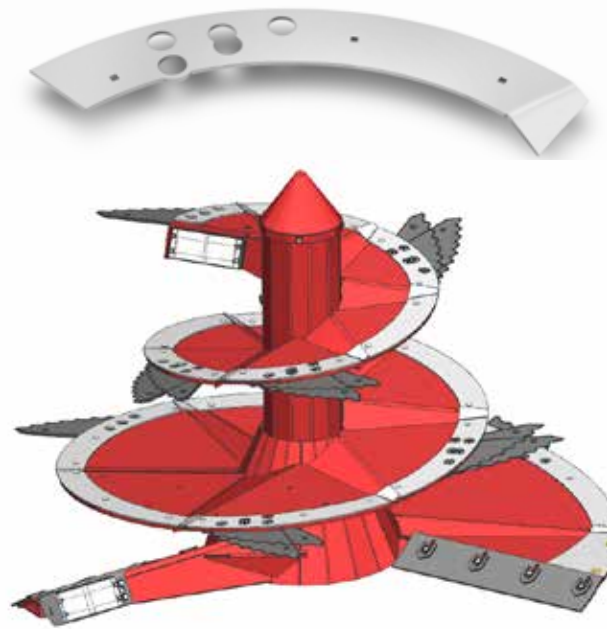

Innodur

Optional "INNODUR" wearing elements significantly extend the service life of the IMS mixing auger.

- 5 mm thick and 100 mm wide stainless steel elements
- Screwed to the auger windings with an overlap
- Quick and easy subsequent mounting also possible
- No labour-intensive welding required

For high demands – Heavy-duty design

When the mixing auger is replaced with a residual thickness of 5 mm:

Standard mixing auger 15 mm

- Wear material 10 mm

Heavy-duty mixing auger 20 mm

- Wear material 15 mm

→ **50% longer service life = 50 % less wear costs**

Stainless steel lining



Fodder rations with a high maize percentage (>75 % of the dry substance content of the total ration), in particular have an increased percentage of aggressive lactic acid. The acid attacks the container material and promotes the formation of rust films. A stainless steel lining for the container effectively prevents this.



- Stainless steel elements
- 1.5 mm thick and 90 cm high side panel elements
- 3 mm thick bottom plate
- Also subsequently available with 3 mm thick side panel elements

Individually equipped for your needs

Special equipment options help you to adapt your IMS mixing auger even better to your individual needs:

-  Short knives as standard
-  Long knives as optional equipment, ideal for undoing straw and baled silage



More safety for your animals!

Protective cover between mixing auger and coaxial gearbox

- Made of robust plastic
- Recommended for compact mixtures (compact TMR) or for addition of larger quantities of water
- Reliable protection against fodder deposits between mixing auger and gearbox

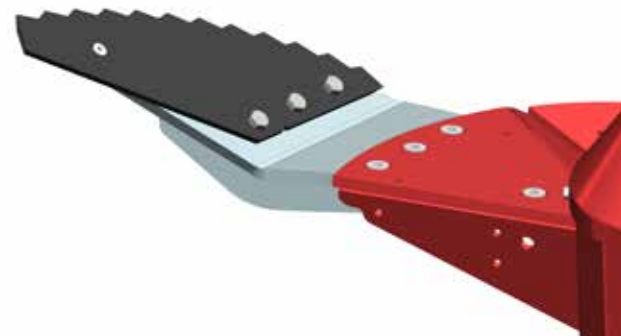

Bale knife
The bale knife is perfectly suitable for undoing round bales.

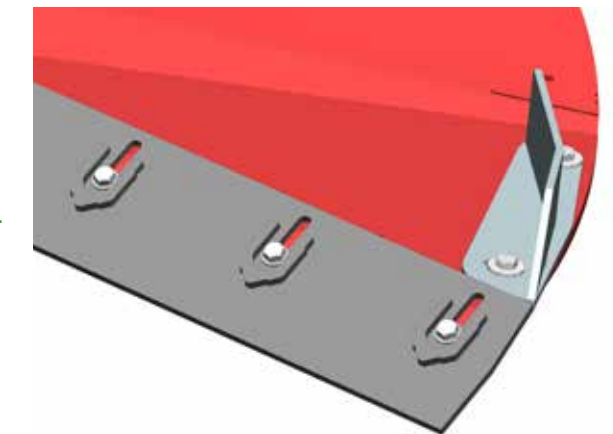

Scraper
"Scrapers" especially developed for very poorly structured feed rations (compact TMR) ensure an additional mixing effect and an improved fodder movement.

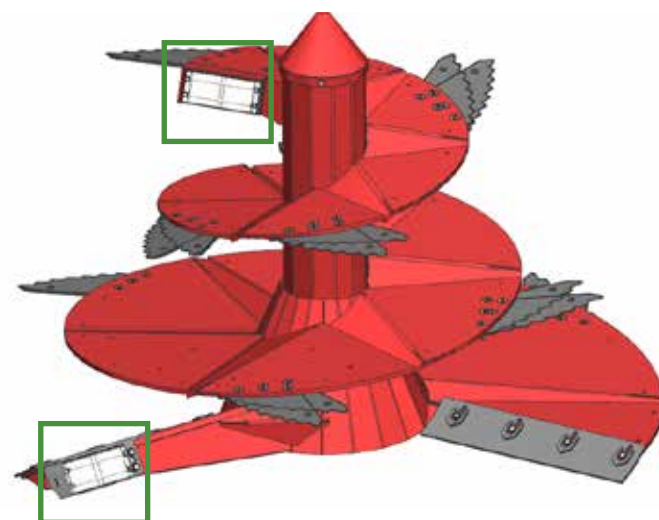
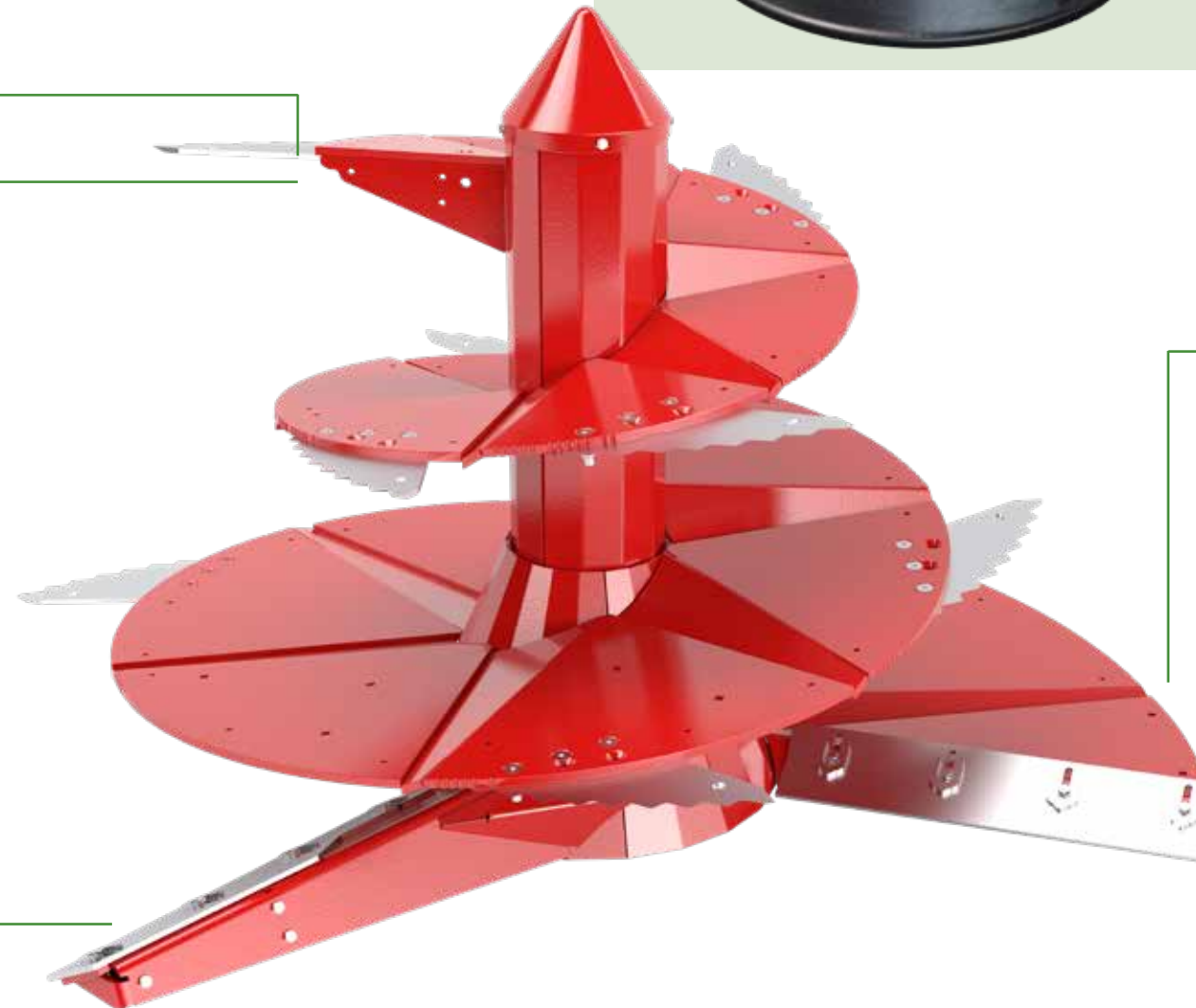

Magnetic system
Each silage and any kind of purchased fodder might contain metallic foreign objects which might harm your dairy cattle. The Strautmann magnetic system (optional) mounted directly at the mixing auger protects your valuable livestock against internal injuries, thus ensuring herd health.

The industrial magnets are mounted such that they have direct and immediate contact with the mixed fodder and thus very effectively filter out metallic foreign objects without them being carried away again from the magnet by the following fodder.



Result after 14 days of using our magnets (wedding ring as reference in the bottom right of the photo)

Discharge and weighing device – Take your choice

Verti-Mix S



The proper discharge for your business

Depending on the individual conditions prevailing in an enterprise, discharge via side doors is possible at different points. Furthermore, slope conveyors of different lengths up to 4.5 m for the transfer to other transport systems are available.

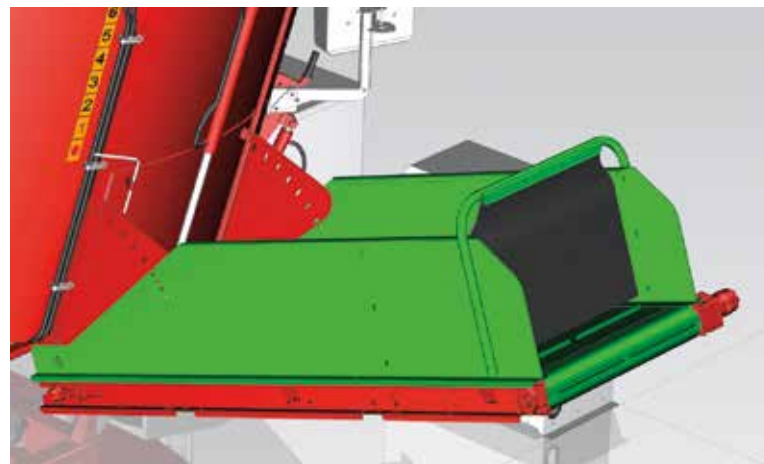

Weighing devices

The weighing device is an integral component of the fodder mixing wagon. Only an exact quantity determination of the individual ingredients ensures full use of the profitability of the fodder mixing wagon. The PTM Advance Super USB weighing device is WLAN compatible, the appropriate software is separately available.



PTM AV 75
Radio remote
control

- 1. PTM HL 50 –programmable weighing device**
The PTM HL 50 is the starter model of the Strautmann weighing devices
- 50 recipes, from 30 ingredients
 - Assessment
 - Acoustic/Visual signal
 - Compatible with radio remote control AV 70 for comfortable operation of weighing computer from the charging vehicle



- 2. PTM Advance Super USB – programmable weighing device**
A complete feeding control including time recording is of fundamental importance for cost optimisation on dairy farms.
- 150 recipes
 - From 99 ingredients, 30 can be used per recipe
 - Multi-Link compatible – several devices can be connected
 - Optional: Wireless communication with farm PC via WLAN antenna

Verti-Mix S

Technical data

	Verti-Mix 951 stationary	Verti-Mix 1651 stationary
Dimensions		
Container ground clearance [m]	0.62-0.77	0.62-0.77
Container height (without extension) [m]	1.56	2.18
Container height (180 mm extension) [m]	1.74	2.36
Container height (360 mm extension) [m]	1.92	2.54
Container length [m]	3.03	3.67
Container width [m]	2.16	2.42
Installation option 1.0		
Distance of gear motor to container centre [m]	2.28	2.28
Distance of base spindles in engine mount to centre [m]	1.69	1.69
Installation option 1.1		
Distance of gear motor to container centre [m]	2.18	2.17
Distance of base spindles in engine mount to centre [m]	1.59	1.59
Transfer conveyor		
Rear slope conveyor 1.4 m		
Max. distance between container bottom and discharge conveyor [m]	1.17-0.99	1.17-0.99
Min. discharge height [m]	0.78	0.78
Rear slope conveyor 2.53 m		
Max. distance between container bottom and discharge conveyor [m]	2.19-1.84	2.19-1.84
Min. discharge height [m]	1.14	1.14

Technical data

	Verti-Mix Double 1700 stationary	Verti-Mix Double 2400 stationary
Dimensions		
Container ground clearance [m]	0.67	0.67
Container height (without extension and inner overflow ring) [m]	1.81	2.31
Container height (without extension and top-mounted overflow ring 155 mm) [m]	1.74	2.36
Container height (with 350 mm extension and inner overflow ring) [m]	2.16	2.66
Container height (with 350 mm extension and top-mounted overflow ring 155 mm) [m]	2.32	2.82
Container length [m]	5.40	6.07
Container width [m]	2.16	2.42
Distance between centre of gear motor and container centre [m]	2.18	2.40
Distance between gearboxes [m]	2.14	2.40
Distance between centre of gear motor and discharge [m]	1.04	1.17
Transfer conveyor		
Rear slope conveyor 1.4 m		
Max. distance between container bottom and discharge conveyor [m]	1.17-0.99	1.17-0.99
Min. discharge height [m]	0.78	0.78
Rear slope conveyor 2.53 m		
Max. distance between container bottom and discharge conveyor [m]	2.19-1.84	2.19-1.84
Min. discharge height [m]	1.14	1.14

Verti-Mix S

Verti-Mix S





www.straumann.com

B. Straumann & Söhne GmbH u. Co. KG



Bielefelder Straße 53
D-49196 Bad Laer
Phone: +49(0)5424/802-0
Fax: +49(0)5424/802-76
info@straumann.com
www.straumann.com